



856HE



BATTERY TYPE	LFP
RATED STORAGE ENERGY	423 kWh
OPERATING WEIGHT	21,000 kg (46,297 lbs)
RATED LOAD CAPACITY	5,800 kg (12,787 lbs)
STANDARD BUCKET SIZE	3.5 m ³ (4.58 yd ³)
STANDARD BREAKOUT FORCE	162 kN (36,419 lbf)
STANDARD DUMP CLEARANCE	2,977mm (9'9")



BATTERY ELECTRIC VEHICLE

TOUGH WORLD. TOUGH EQUIPMENT.

CHANGE FOR THE BETTER

LET'S TALK CHANGE

If you are reading this, then in all probability you are considering making the change to electric machines.

But how do you go about it? Who offers the best machines, support and advice? Who offers the best total cost of ownership? What kind of return on investment can you expect?

As a leader in electric machine and infrastructure technology, we believe we can guide you through every step of your change to electric.

WHY ELECTRIC?

Fully electric? Hybrid?
Alternative fuel transmissions?

Making the change from diesel presents a number of options and LiuGong have fully evaluated all of the above and more before deciding on electric as the best option.

WHY CHANGE NOW?

Our global priorities for energy are changing rapidly, with the adoption of electric power accelerating beyond all other sources. For our customers, changing to electric is a strategic change for the better.

At LiuGong, we can relate to this. We want to be a better global citizen and help make life better for everyone. This thinking has shaped our investment and transformation into a leader in electric capability.





DECARBONIZATION

Reaching our target with electric technology

CO₂

BETTER EFFICIENCY

Work efficiency increases by

20%

compared with the diesel alternative

BETTER ECONOMY



1

 electric unit can save

150L

 of fuel per day*

That equates to over

37,500L

 of fuel per year**, saving up to

125kg

 of carbon emissions.

*based on 10 hours at 15L/hour.
**based on 2,500 hours

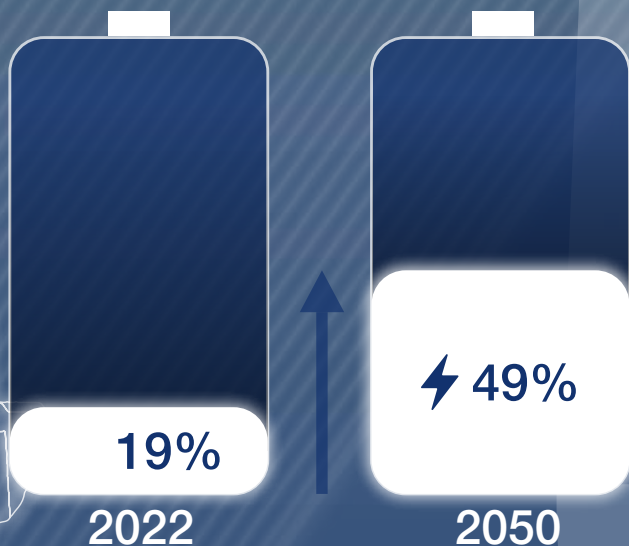

Our energy priorities are changing fast.

Now is the time to change for the better. Together we can help reduce CO₂ emissions by over

50

 MILLION TONS

LEADING IN BATTERY ELECTRIC VEHICLE TECHNOLOGY

WE OFFER A WORLD LEADING BEV RANGE

LiuGong were one of the first Chinese construction equipment manufacturers to identify the potential of battery electric vehicles in our industry.

As a leader in BEVs we are already developing one of the world's largest electrically powered construction equipment ranges.

In the last 8 years alone, we have invested over 100 million CNY in R&D and product development and testing.

Covering 9 product areas, from aerial access equipment to heavy-weight excavators and wheel loaders, we are changing the face of the industry.

2014

Start of EV technology development

2018

World's first EV loader and excavator built by LiuGong

December 2020

Launch of the first-generation EV loader and excavator

WE ARE A WORLD LEADER IN BEV DESIGN AND R&D

Our Design and R&D Teams are driven to produce the widest possible range of electric vehicles with the toughness, intelligence and performance you would expect from LiuGong.

Sharing our Red Dot award winning design DNA, our BEVs have already been awarded with Top 50 Innovation Gold Award in 2021 and Top 50 Energy Gold Award in 2022.

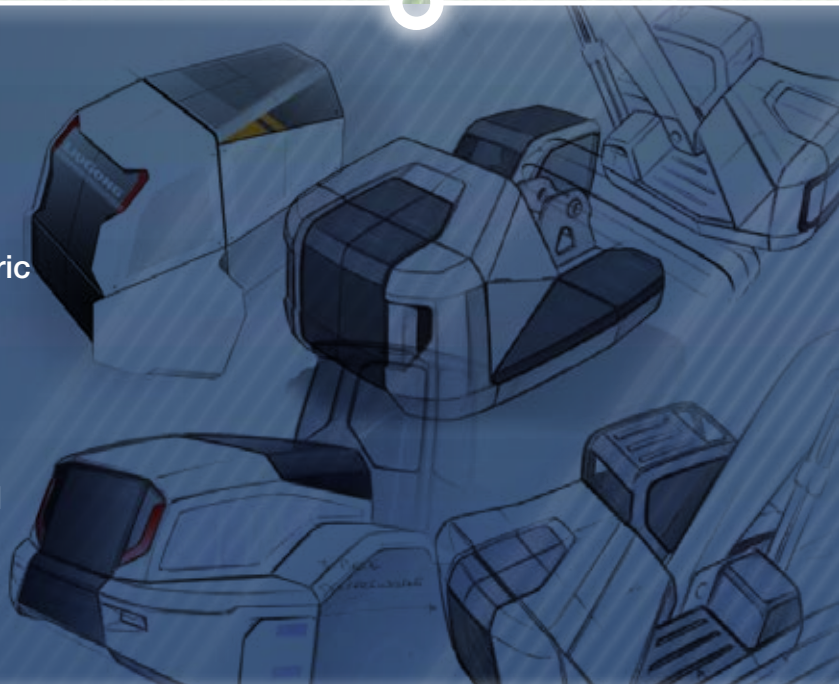

ELECTRIC PRODUCT LINES



WHEEL LOADERS



EXCAVATORS



ROLLERS



MINING TRUCKS



SKID STEER LOADERS



FORK LIFTS



AERIAL ACCESS EQUIPMENT

April 2021

EV loader won the top 50 innovation gold award 2021

March 2022

Top 50 new energy gold award 2022

May 2022

Sales of EV wheel loader ranks first in the world

TRUST OUR EXPERIENCE TO HELP YOU CHANGE



NEW 856HE

AN INTELLIGENT SOLUTION FOR A TOUGH WORLD

To justify the change to electric, BEVs must outperform conventional machines. Our new 856HE MAX is all the justification you need.

It's a machine with proven performance in the areas you really care about.



INTELLIGENCE & CONTROL

- Our intelligent, human centric design creates a superior operator experience.
- Load-sensing hydraulics
- EAT700 transmission with electro-proportional valve for fast and smooth shifting
- Independent control of dual-motor drive for maximum hydraulic lift



SAFETY & COMFORT

- Designed around the operator our cab provides the highest levels of safety, visibility and comfort.
- Micro-pressurized cab significantly reduces dust and noise contamination
- ROPS protection



POWER & BATTERY PERFORMANCE

Working with world-leading battery manufacturer CATL, the 856HE MAX is powered by a 423 kWh large capacity lithium iron phosphate battery.

- 11.7 hr working time capability (light applications) & 8.6 hours (heavy applications)
- 1.7 hr fast charging capability (240kW)
- Intelligent Battery Management System



PLUG & PLAY SIMPLICITY

We help you change to electric by offering a simple a plug & play solution, perfectly matched to deliver the optimum performance, economy and safety.

- BEV machine
- Charging infrastructure
- Health and safety training and support



ENVIRONMENTALLY FRIENDLY

Heavyweight performance with environmental responsibility.

- Zero Fuel
- Zero Emissions
- Lower noise & vibrations



GUARANTEED RELIABILITY

We already have over 1,000 electric wheel loaders operating in the toughest conditions, so we go further to give you peace of mind.

- 5 year or 10,000 hours warranty (for battery, motor, controller) as standard
- IP67 rated wiring harness
- Waterproof integrated battery package

CHANGE FOR INTELLIGENT PERFORMANCE



WORK SMARTER. NOT HARDER

The 856HE MAX gives you the option to specify LiuGong's Intelligent Shovelling System. This smart technology automatically carries out repetitive shovelling cycles reducing operator fatigue.



AUTOMATIC CONTROL

LiuGong's electric control box linked to an electric proportional transmission with a direct connection to the travel motor delivers the optimum torque with minimum energy. This smart solution improves transmission efficiency by more than 20% compared with conventional machines.



BETTER BATTERY PERFORMANCE

The 856HE MAX is powered by a 3-battery pack developed with world-leading manufacturer CATL. But we've used our intelligent design to make the best even better.

Batteries deliver their optimum performance when operating at temperatures of between 20°C and 35°C. Our battery pack uses LiuGong's Intelligent Thermal Management System to keep the working temperature at its optimum. Better design. Better performance. That's intelligence.



HIGHER LOADING POWER. FOR +10% LESS FUEL

The 856HE MAX benefits from LiuGong's new, intelligent hydraulics. This smart, fully electric system eliminates bypass throttling and overflow loss, improving hydraulic control and reducing energy consumption by more than 10% compared with conventional technologies.



MAKING THE MOST OF EVERY CHARGE

For BEVs, fuel consumption may no longer be an issue, but energy efficiency is still a top priority for LiuGong. Our machines are required to work in the toughest, most remote locations, so it's essential that they use their battery power intelligently. Our smart approach differentiates our BEVs and makes the most of every charge.



MAXIMUM COOLING. MINIMUM ENERGY

With intelligent temperature control, the 856HE MAX cools and protects with unrivalled efficiency. Each fan has independent control and can operate automatically in forward and reverse rotation. Cleaner, cooler, more efficient. That's smart.



CHANGE FOR A SAFER SOLUTION



SAFETY WITHOUT COMPROMISE

With active and passive safety protection our aim is to create the safest working environment yet. Designed around the operator, our cab provides the highest levels of safety, visibility and comfort. ROPS protection, advanced battery technology and excellent overall construction all combine to create zero tolerance for accidents in or around the machine. No one protects you or the environment more.



SAFE AND SECURE

Our approach to battery management is simple. We keep our batteries safe, secure and in top condition to give you performance you can rely on.



SAFETY FIRST

Our charging gun has been designed with simplicity and safety in mind and prevents the operator from potential electrical hazards such as shocks, short circuits and over-charging. It's a simple, safe solution that gets you back on the job, fast.



IP67 ASSURANCE

Every electrical component on the 856HE MAX meets the IP67 standard for dust-proof and waterproof performance, and has a wading depth of 750mm.

As you would expect, the 3 battery packs easily meet the IP67 standard and have been designed to withstand the harshest working environments of extreme heat and humidity.

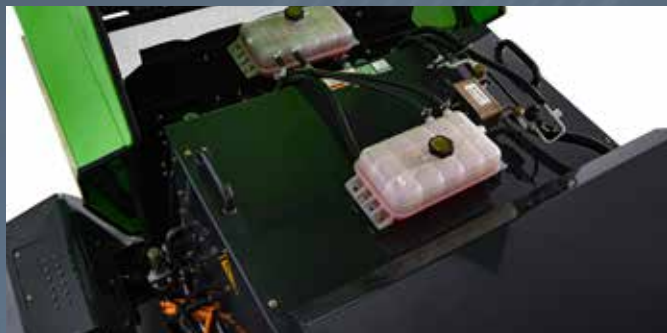

CHANGE FOR COMFORT



ENVIRONMENTALLY FRIENDLY

Changing to electric brings you the obvious benefits of zero emissions and zero diesel costs. But our new design for the 856HE MAX goes even further.

‘Silent’ is a bold claim, but noise performance tests prove that internal and external noise and vibrations are negligible, compared with traditional machines. Zero noise is our aim, and the new 856H comes within a whisper of achieving that.



NO VIBRATIONS

Shock absorption technology protects the battery system even in the toughest conditions, whilst charging and discharging technology maintains and extends battery life.





DESIGN COMFORT WORK ENVIRONMENT



CHANGE FOR 'PLUG & PLAY' SIMPLICITY



PLUG & PLAY SIMPLICITY

We help you change to electric by offering a simple plug-and-play solution, perfectly matched to deliver the optimum performance, economy and safety.



POWER & BATTERY PERFORMANCE

We've made the change to electric easy with an 'all-in-one unit' powertrain, designed for optimum simplicity and performance, and an intelligent battery management system for a safe and easy charging solution.



ALL IN ONE POWERTRAIN

Our All-In-One Powertrain seamlessly integrates controller, travel motor, transmission, drive axle controller, and hydraulic motor and pump into a single system. That means maximum power with maximum efficiency.



SUPERIOR BATTERY PERFORMANCE

Working with world-leading battery manufacturer CATL, the 856HE MAX is powered by a 423 kWh large capacity lithium iron phosphate battery. Delivering:

- 11.7 hour working time capability (light applications) 8.6 hours (heavy applications)
- 1.7 hour fast charging capability (240kW)



up to
11.7
HOURS

working time in
light applications

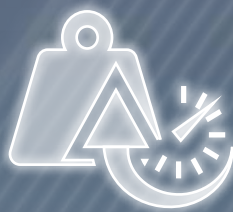

up to
8.6
HOURS

working time in
heavy applications



1.7
HOUR

fast charging
capability



CHANGE WITH CONFIDENCE



GUARANTEED RELIABILITY

As you would expect, the 856HE MAX has reliability built in. The machine has been proven to be reliable in harsh working conditions such as 5000m above sea level, sub-sea tunnels, ports, and sand and coal fields, meeting the needs of various working conditions. In addition, the IP67-rated wiring harness adds extra protection to the battery, motor and electronic control system and a waterproof integrated battery package keeps the battery safe in wet conditions or during jet wash cleaning.

But we go further to guarantee your peace of mind. Our new 856HE MAX comes with a 5 year, 10,000 hours (for battery, motor, controller) warranty as standard.

This is not a sales gimmick. This guarantee underlines the confidence we have in our electric machines, born out of real-life controller) perience in tough, commercial job sites.

5 YEAR **10,000**
HOURS WARRANTY



TUNNELS



POWER PLANTS



STEEL MILLS



PORTS



CEMENT PLANTS



SAND PLANTS



BATCH PLANTS



CHANGE FOR BETTER RETURN ON INVESTMENT



DIESEL VS ELECTRIC?

This is the big question. In a straight cost-per-ton comparison, changing to electric makes sense on the job site and on the balance sheet. Diesel wheel loaders use 1 litre of oil, while electric wheel loaders use only 3 kWh of electricity.

LOW TOTAL COST OF OWNERSHIP

- Permanent magnet synchronous motor
- Maintenance-free battery

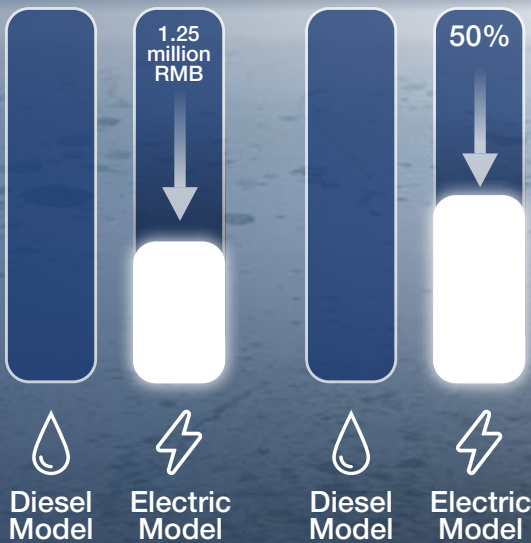



SLASHES OPERATIONAL & MAINTENANCE COSTS

Not guesswork – but cold, hard fact, gleaned from over 200 customer job sites. Our detailed analysis proves that our electric machines reduce 5-year operational costs by up to 70% and maintenance costs by up to 50%.

Add to this LiuGong's 5 year, 10,000 working hours warranty (for battery, motor, controller) and the New 856HE MAX promises exceptional return on investment.



RECHARGES WHILE YOU WORK

It would be impossible for a conventional machine to create its own diesel, but LiuGong's intelligent energy recovery system actually charges the battery as you work. This smart technology saves up to 20% of energy and keeps you working longer between charges.



USE OUR SMART APP

You can calculate your total cost of ownership in an instant with our smart app. Try it now. It could change your mind for the better.



NEW 856HE



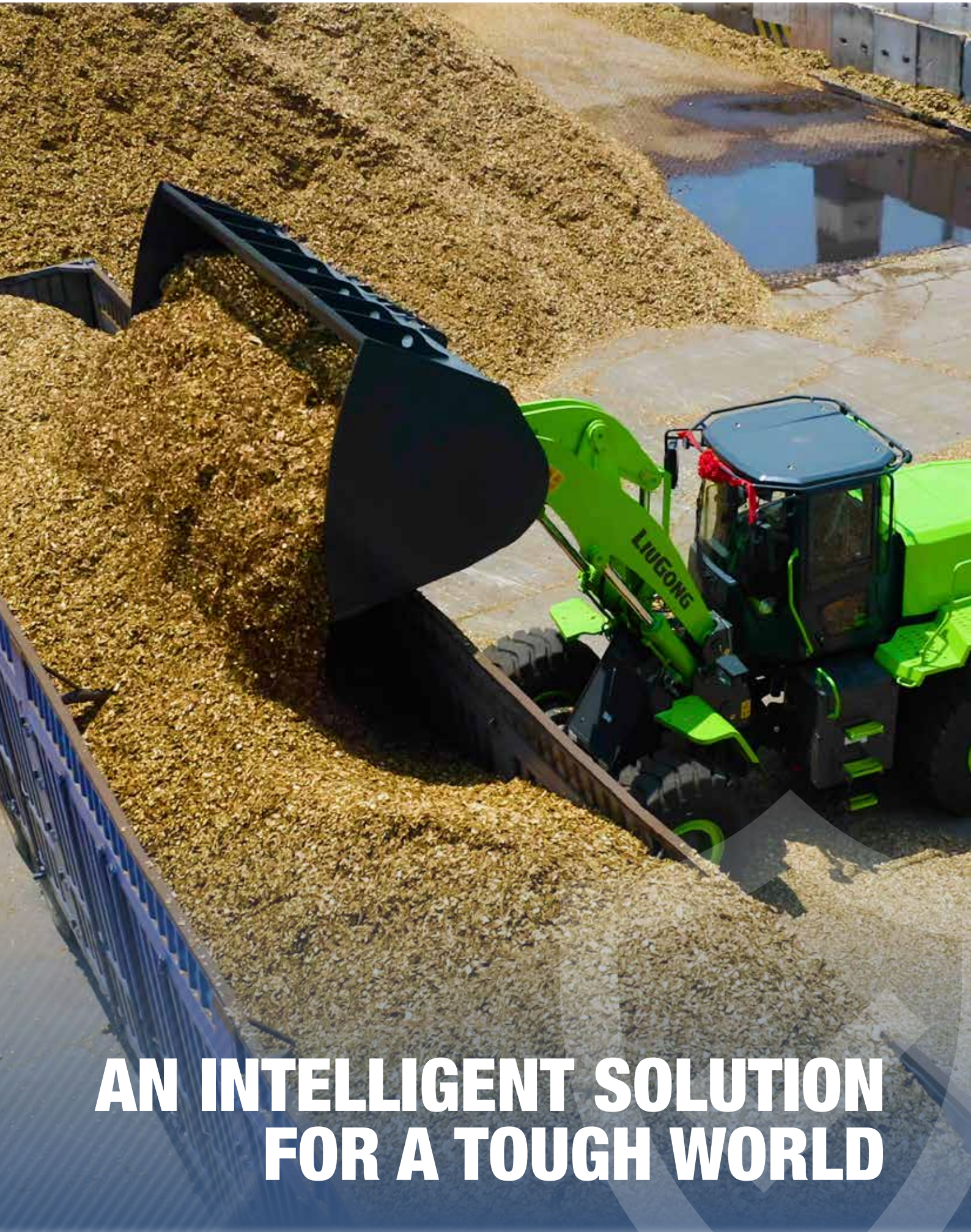

AN INTELLIGENT SOLUTION FOR A TOUGH WORLD

856HE



SPECIFICATIONS >>>

Operating weight	21,000 kg (46,297 lbs)
Operating weight includes the machine weight with standard work device, no additional equipment or accessories, full fuel tank, all fluids at required level and an operator 75 kg.	
Bucket capacity range	2.7~5.6 m³ (3.53~7.32 yd³)

POWER BATTERY	
Description	
Battery Type: lithium iron phosphate batteries Drive motors & hydraulic motors: Made by INOVANCE Ambient Temperature: -40~85°C.	
Manufacturer	CATL
Model	LFP
Rated Storage Energy	423 kWh
Nominal Voltage	618 V
Protection class of battery system	IP67
Cooling method	Intelligent temperature control, liquid cooling
Optional charging pile specifications	≤360 kW (≤ 482.8 hp)
Charging time (300 kW charging pile)	≤90 min (fast charging)

TRANSMISSION	
Description	
Transmission: LiuGong EAT700 planetary, power shift transmission, with an integrated pilot single joystick and FNR. The electric proportional valve provides a smooth and continuous variation in flow ensuring fast response when shifting. Number of Speeds: Forward 2, reverse 1	
Transmission type	Planetary, power shift
Maximum travel speed, fwd	40 km/s (24.9 mph)
Maximum travel speed, rev	13 km/s (8.1 mph)
Number of speed, fwd	2
Number of speed, rev	1

HYDRAULIC SYSTEM	
Description	
System Supply: A variable displacement piston work pump and a variable displacement piston steering pump. Steering always takes priority. Valves: Patented closed median main control valve. Lift Function: The valve has four positions: lift, hold, lower, and float. Inductive/magnetic automatic boom kick-out can be switched on and off and is adjustable to two positions: bucket at ground Level and maximum reach full lifting height. Tilt Function: Realize compound action - boom lifting and discharging simultaneously. Cylinders: Double-acting cylinders for all functions.	
Main pump type	Variable displacement pump
Controls	Electric proportional fingertip control
Main relief pressure	25 MPa (3,626 psi)
Raise	5.2 s
Dump time	1.5 s
Float down time	2.3 s
Fastest total cycle time	9.0 s

DRIVE MOTOR	
Power	160 kW (215 hp)
Ambient temperature	-40~85°C
Adaptive altitude	≤5,000 m (3.1 mile)

STEERING	
Steering configuration	Articulated
Steering relief pressure	21 MPa (3,046 psi)
Maximum flow	100 L/min (26.4 gal/min)
Steering cylinders	2
Cylinder bore	90 mm (2")
Rod diameter	50 mm (4")
Stroke	395 mm (1'4")

AXLES	
Front and rear axle reduction ratio	23.3
Axle oscillation	±9°

ELECTRICAL SYSTEM	
Description	
The central warning system includes central warning light and buzzer for the following functions: power battery fault alarm, motor fault alarm, insulation fault alarm, charger connection alarm, shutdown alarm, etc. When working, the central warning light and buzzer are used for the following functions: power battery & travel motor & hydraulic motor temperature display, battery power display, brake low pressure alarm, parking brake indicator, transmission oil pressure alarm, etc.	
Voltage	DC 24 V
Batteries	2×12 V
Battery capacity at 20h rate	120 Ah
Cold cranking capacity at -18°C	850 A
Reserve capacity	224 min

SOUND & ENVIRONMENT	
Sound level in cab (travel mode) according to iso 6396-2008/en iso 3744-1995	/
Sound level in cab (stationary work cycle mode) according to iso 6396-2008/en iso 3744-1996	/
External sound level (travel mode) according to iso 6396-2008	/
External sound level (stationary work cycle mode) according to iso 6396-2008	/
Ventilation	14 m³/h (18.3yd³/h)
Heating capacity	7 kW (9 hp)
Refrigerating capacity	5.5 kW (7 hp)



BRAKES

Description	
New electro-hydraulic proportional braking system	
Service brake type	Full hydraulic
Parking brake type	Drum
Parking brake actuation	Hydraulic cylinder brake

CAB

Description	
Instrumentation: All important information is centrally located in the central instrument panel and operator's field of vision. Large curved front window glass and rear mirrors ensure great visibility.	
Adjustable steering column, high back seat, armrest box and A/C with all-around air outlets are provided as standard.	
Pressurized cab with lower interior noise.	
The cab is tested and approved according to ROPS (ISO 3471), FOPS (ISO 3449).	

DIMENSIONS

E Ground clearance	431 mm (1'5")
G Wheelbase	3,525 mm (11'7")
H Cab height	3,500 mm (11'6")
J Wheel tread	2,280 mm (7'6")
K Width over tires	2,880 mm (9'5")
L Length with bucket down	8,615 mm (28'3")
M Turn angle, either side	38°
P Rear angle of departure	28°
R1 Turning radius, bucket carry	7,209 mm (23'8")
R2 Turning radius, outside of tire	6,625 mm (21'9")
W Width over bucket	2,970 mm (9'9")

SERVICE CAPACITY

Cooling system	45 L (12 gal)
Hydraulic system	230 L (61 gal)
Transmission and torque converter	30 L (8 gal)
Axles, front/rear	35 L (9 gal)

LOADER ARM PERFORMANCE WITH ATTACHMENT

Tipping load - straight (iso 14397-1:2007)	17,400 kg (38,360 lbs)
Tipping load - full turn (iso 14397-1:2007)	15,400 kg (33,951 lbs)
Bucket breakout force	162 kN (36,419 lbf)
A Maximum hinge pin height	4,156 mm (13'8")
B Dump clearance at full height discharge	2,977 mm (9'9")
C Dump reach at full height discharge	1,231 mm (4')
D Maximum digging depth, bucket level	50.2 mm (2")
S1 Bucket rollback at ground level	44.3°
S2 Bucket rollback at carry	49°
S3 Bucket rollback at maximum height	56°
S4 Maximum dump angle at full height	45°

TIRES

Tire size	23.5R25 ★ L-3
-----------	---------------

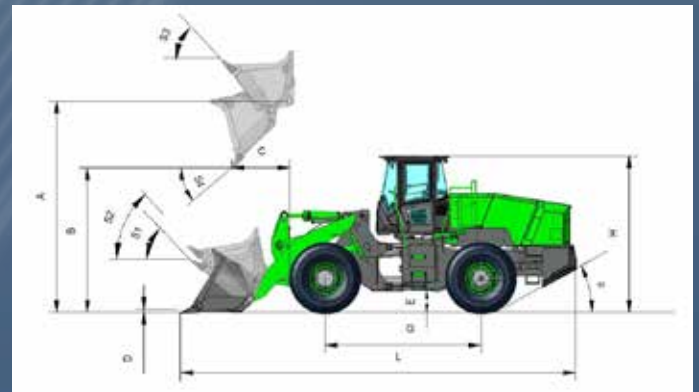
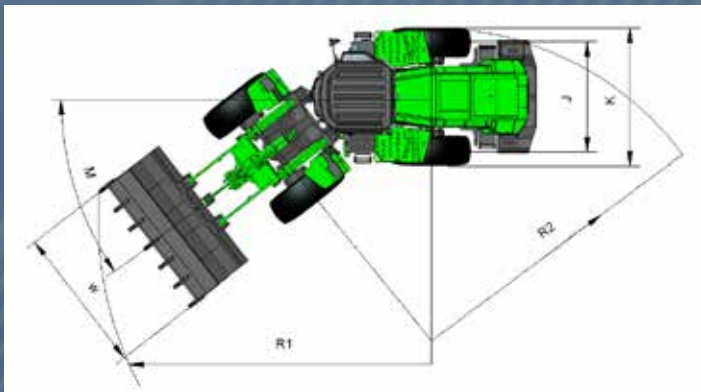

STANDARD EQUIPMENT

POWER SYSTEM

- CATL battery, INOVANCE drive motor and pump motor
- Intelligent temperature-controlled liquid cooling
- Electronic controlled fan with automatically speed adjustment, and auto reversing functions

TRANSMISSION

- LiuGong EAT700 automatic planetary electric control transmission

AXLE

- LiuGong wet axles
- Front & rear limited slip differentials
- Parking brake service as secondary

HYDRAULIC SYSTEM

- Closed-center variable displacement load sensing system
- 3-spool main valve
- Integrated pilot single joystick with FNR
- Ride control
- Load holding valve

STEERING SYSTEM

- Load sensing system with flow amplification and steering priority
- Secondary steering system

TIRE & RIM

- Radial tire, 23.5R25 ★ L-3
- Tire nozzle protection

CHASSIS FRAME

- Spacious central articulation arrangement with beval bearing
- Articulation locking bar
- Tow hitch

OPERATOR STATION

- Pressurized cab, with FOPS&ROPS
- Steering column, up & down, front & rear multiple direction adjustable
- Air-suspension seat, electrically heated, high back, armrest, headrest, multi-direction adjustable
- Full LCD front instrument panel
- Indicators: high & low beams, locking status, parking brake, direction, lubrication system, battery charging, operation ready, etc.
- AC system
- Instrument: voltage, motor speed, fault code, SOH/SOC, battery temperature, hour meter, etc.
- Fresh air circulation system
- Electrically heated rearview mirrors
- Front and rear sun visors
- Back-up alarm
- Rear view camera
- Electric horn
- Fire extinguisher
- Cab rear windshield defroster
- Rotating beacon

OTHERS

- Automatic centralized lubrication

- Fenders
- Liugong telematics
- Light protective guard
- Boom supporting brackets

OPTIONAL EQUIPMENT

HYDRAULIC SYSTEM

- 4 SPL valve
- 3 SPL valve

TYRE & RIM

- Bias, tube tire
- Wide base tire

OPERATOR STATION

- Cab dust removal device
- One button start
- 360 panoramic view camera
- Backup radar
- Steering joystick
- Payload

LINKAGE & ATTACHMENTS

- Quick coupler
- High/extra-high linkage
- Snow pushing device
- Rock bucket
- Side dump bucket
- High dump bucket
- Grapple

PROTECTIVE DEVICE

- Chassis guard
- Protection guard of cab
- Tire chain

OTHERS

- Low temperature package
- Landfill package
- HID lamp (Top of cab)





A TEAM YOU CAN TRUST



TALK TO US TODAY

T: +86 772 3886124
E: overseas@liugong.com
www.liugong.com





TRUCK & EQUIPMENT SERVICES SA
17, rue des Martyrs
L-7375 LORENTZWEILER
+352 33 34 35
info@tes.lu
www.tes.lu

Guangxi Liugong Machinery Co., Ltd.

No. 1 Liutai Road, Liuzhou, Guangxi 545007, PR China
T: +86 772 3886124 E: overseas@liugong.com
www.liugong.com

LG-PB-856HE MAX-423kW-28-14032023-ENG



The Liugong series of logos herein, including but not limited to word marks, device marks, letter of alphabet marks and combination marks, as the registered trademarks of Guangxi Liugong Group Co., Ltd. are used by Guangxi Liugong Machinery Co., Ltd. with legal permission, and shall not be used without permission. Specifications and designs are subject to change without notice. Illustrations and pictures may include optional equipment and may not include all standard equipment. Equipment and options varies by regional availability.