

STERLING TECHNOLOGY
PRESENTATION
& PRODUCT LINE



STERLING SIDE GRIP PILE DRIVERS

/ JOB APPLICATION

Significantly wider offering & 4 market segments enable further success

SEA SIDE



RIVER SIDE



HEAD ROOM CONSTRUCTION



CONFINED SPACE JOB SITE

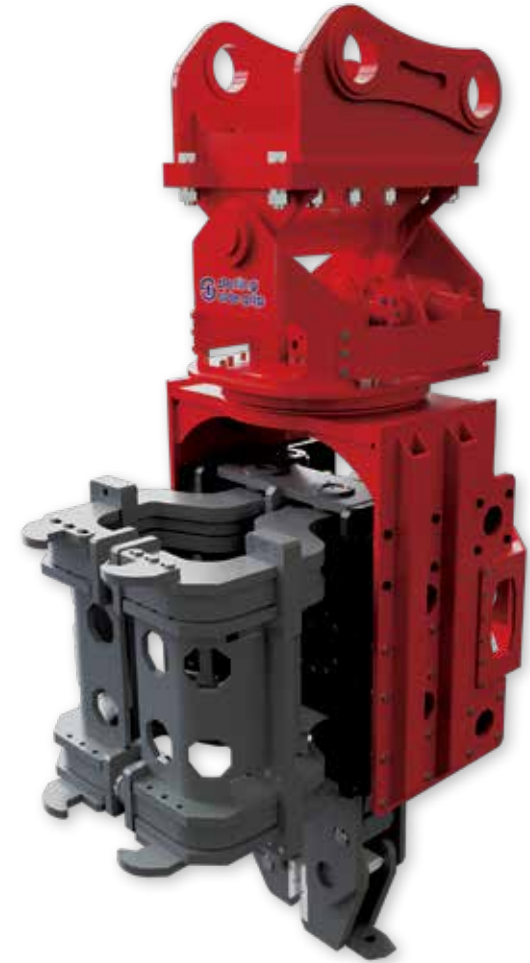

STERLING SIDE GRIP PILE DRIVERS

Side grip type excavator-mounted vibratory pile driver



Model	Unit	SG25	SG30	SG40
Suitable Excavator	ton	20 ~ 26	28 ~ 36	36 ~ 50
Weight (Incl. Mounting Cap)	kg	2,820	3,300	3,800
Setting Pressure	bar	300	300	300
Oil Flow	lpm	170 - 200	180 - 220	240 - 260
Centrifugal force	kN	520	610	700
Frequency	bpm	2,800 ~ 3,600	2,800 ~ 3,600	2,200 ~ 2,800
Rotation	deg	360	360	360
Dimension (A x B x C)	mm	1,515 x 1,040 x 2,833	1,515 x 1,040 x 2,833	1,560 x 1,110 x 2,918
Tilting degree	deg	±30	±30	±30
Bottom Jaw open	mm	65	65	65
Side clamp open	mm	352	352	352
Min Pile Grip Ø	mm	76	76	76
Max Pile Grip Ø	mm	609	609	609

※ Specifications above are subject to change without notice.

FEATURES FOR STERLING SIDE GRIP

- Available for a wide ranges of piles
 - Sheet piles, H beams, I-H beams, and round-piles
- Versatile piling at headroom job site
- Versatile piling at a confined space job site
- Precise and accurate side clamping
 - 360-degree Swivel rotatable grip pads enable precisely and accurately clamping
- Quicker and more powerful
 - Faster penetration and extraction than other side grip pile drivers thanks to bigger and double eccentric weight
- Low maintenance cost & easy maintenance
 - Concise structure of components
- Rigid and durability
 - Balanced counter weighs and rigid rubber cushion

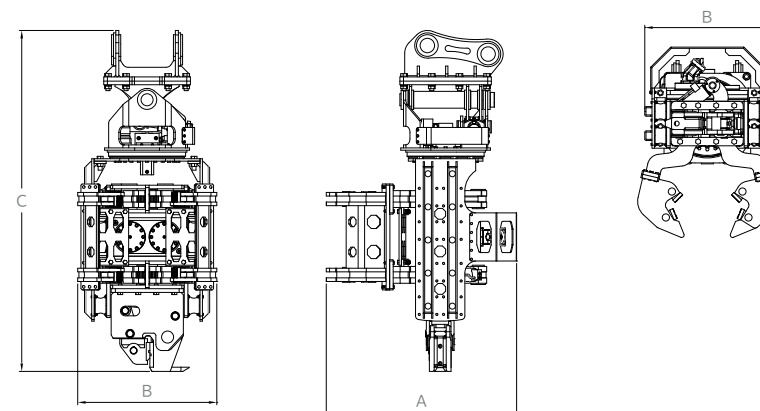

MODEL SELECTION GUIDE

Please refer to the following selection table for selecting suitable Sterling side grip models for the excavators

SELECTION TABLE

Excavator size	36-50ton	28-36ton	20-26ton
Pile size(length/weight)			
6m/2800kg	SG40	SG30	SG25
12m/1900kg			
16m/1300kg			
8m/2300kg			
12m/1800kg			
16m/1200kg			
6m/1200kg			
8m/1000kg			
10m/900kg			
Suitable piles			
Sheet piles	width 400 ~ 1,200mm, depth 265mm		
H-beams/Round-piles	Max 500 x 300 / Max Ø 609mm		

※Please take into consideration for oil flow/pressure, lifting capacity/stability of excavators, soil and site conditions.

Model	Unit	SG25	SG30	SG40
Suitable Excavator	ton	20 ~ 26	28 ~ 36	36 ~ 50
Bottom Jaw open	mm	65	65	65
Side clamp open	mm	352	352	352
Min Pile Grip Ø	mm	76	76	76
Max Pile Grip Ø	mm	609	609	609

※ Specifications above are subject to change without notice.

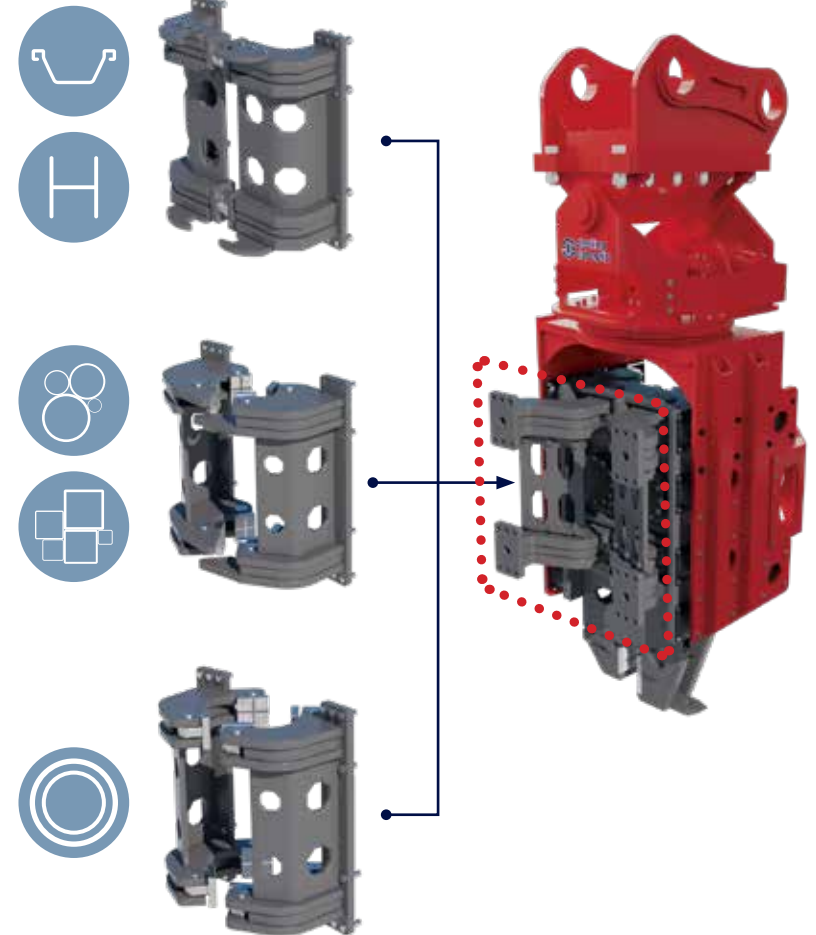

CLAMP SELECTION GUIDE

The following clamp selection guide provides the general guidelines for selecting the correct clamp for the different types and sizes of piles

CLAMP OPTION SPECIFICATION



Standard clamp

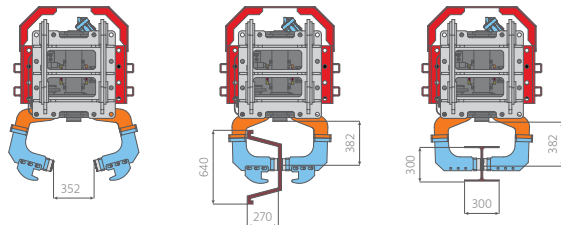

Round pile clamp(S)

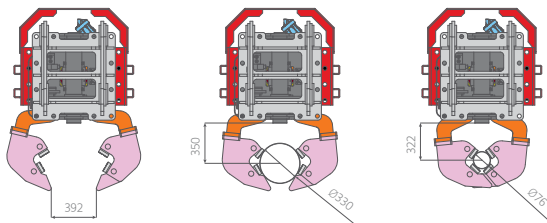

Round pile clamp(L)

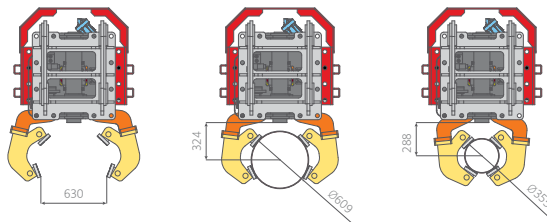

INTERCHANGEABLE CLAMP OPTION

Thanks to its interchangeable side clamp system, the Sterling Side Grip pile driver can handle all types of piles with its multiple clamps, and it offers quick transfer capability between various applications.

Round pile clamp(S) and round pile clamp(L) are an option.

NO NEED TO CHANGE ROUND CLAMP(L) UPTO Ø609MM

Contact us for bigger than Ø609mm - sterling@sterlingripper.com

Standard clamp

Round pile clamp(S)

Round pile clamp(L)



For sheet piles and H beams



For round shape piles sized from 76mm to 330mm
Square 150mm to 250mm
For other size, contact sterling@sterlingripper.com



For round shape piles sized from 355mm to 609mm



STERLING SIDE GRIP-W TYPE

/ JOB APPLICATION

Significantly wider offering & 4 market segments enable further success

SEA SIDE



RIVER SIDE



HEAD ROOM CONSTRUCTION



CONFINED SPACE JOB SITE



STERLING SIDE GRIP-W TYPE

Side grip type excavator-mounted vibratory pile driver



Model	Unit	SG25W	SG30W
Suitable Excavator	ton	17 ~ 26	22 ~ 36
Weight(Incl. Mounting Cap)	kg	2,620	2,800
Setting Pressure	bar	300	300
Oil Flow	lpm	170 - 200	180 - 220
Centrifugal force	kN	520	610
Frequency	bpm	2,800 ~ 3,600	2,800 ~ 3,600
Rotation	deg	360	360
Dimension(A x B x C)	mm	1,165 x 1,189 x 2,600	1,165 x 1,189 x 2,600
Tilting degree	deg	±30	±30
Bottom clamp open	mm	65	65
Side clamp open	mm	255	255

※ Specifications above are subject to change without notice.

FEATURES FOR SIDE GRIP - W TYPE

- Available for a wide ranges of piles
 - Sheet piles, H beams, and I-H beams
- Versatile piling at headroom job site
- Versatile piling at a confined space job site
- Precise and accurate side clamping
 - Balanced four pads allows firmly, precisely and accurately clamping
- Quicker and more powerful
 - Faster penetration and extraction than other side grip pile drivers thanks to bigger and double eccentric weight
- Low maintenance cost & easy maintenance
 - Concise structure of components
- Rigid and durability
 - Balanced counter weights and rigid rubber cushion

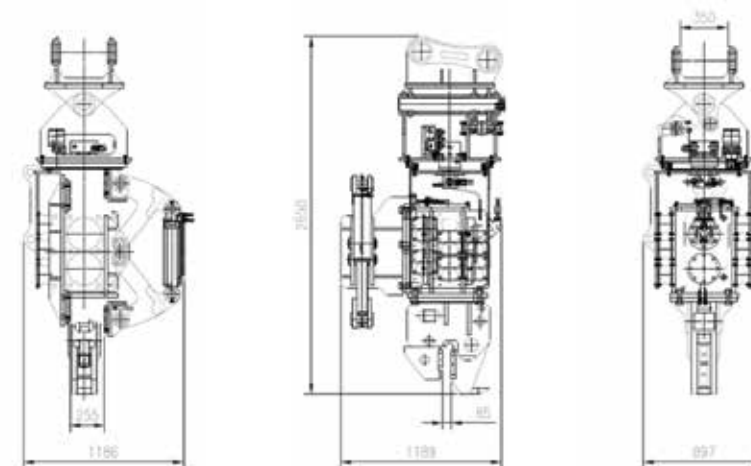

ADVANTAGE OF STERLING SIDE GRIP-W TYPE

- ▶ Sterling “W” type Side clamping
- “W” shape clamp structure of Sterling Side grip - **Precise and accurate side clamping**

Conventional Side grip clamping unit

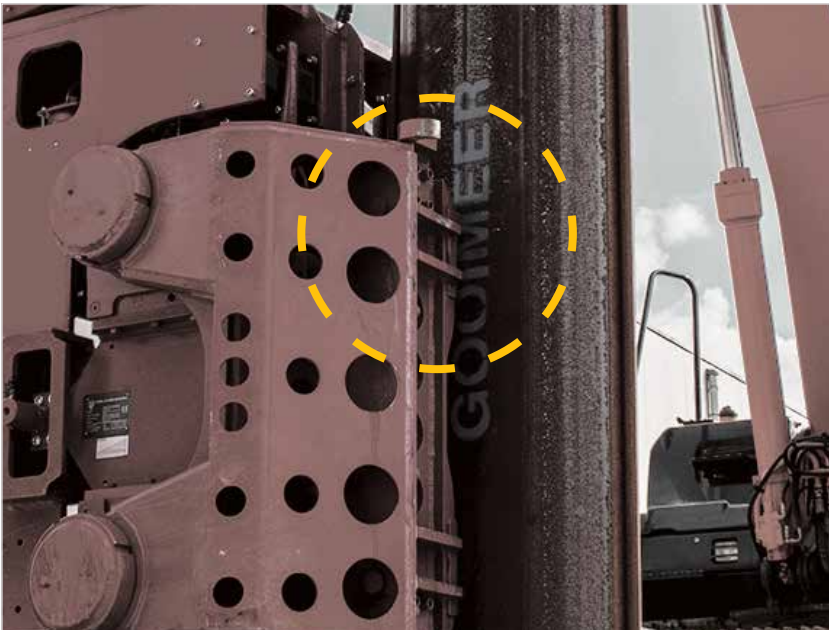

Four fixed clamping pads with two separate arm structure may cause inaccurate clamping. Frequent inaccurate clamping may lead to crack or damage of clamping cylinder and clamp arm.

VS

Sterling Side grip - W type clamping unit



“W” shape clamp structure and balanced four pads allows firmly, precisely and accurately clamping all the time.

SELECTION GUIDE / SHEET PILES & H BEAM ONLY

Please refer to the following selection table for selecting suitable Sterling side grip models for the excavators



SELECTION TABLE

Excavator size	25-36ton	20-24ton
Pile size(length/weight)		
8m/2300kg	SG30W	SG25W
12m/1800kg		
16m/1200kg		
6m/1200kg		
8m/1000kg		
10m/900kg		
12m/8500kg		
Suitable piles		
Sheet piles	Width 400 - 1,200m, Depth 250mm	
H-beams	180x500mm	

※ Please take into consideration for oil flow/pressure, lifting capacity/stability of excavators, soil and site conditions.

Model	Unit	SG25W	SG30W
Suitable Excavator	ton	17 ~ 26	22 ~ 36
Bottom Jaw open	mm	65	65
Side clamp open	mm	255	255
Max Pile Grip Ø	mm	250	250

※ Specifications above are subject to change without notice.

STERLING AUTO TILT HAMMER

/ JOB APPLICATION

Significantly wider offering & 4 market segments enable further success

SEA SIDE



RIVER SIDE



SAND FIELD



WITH AUGER

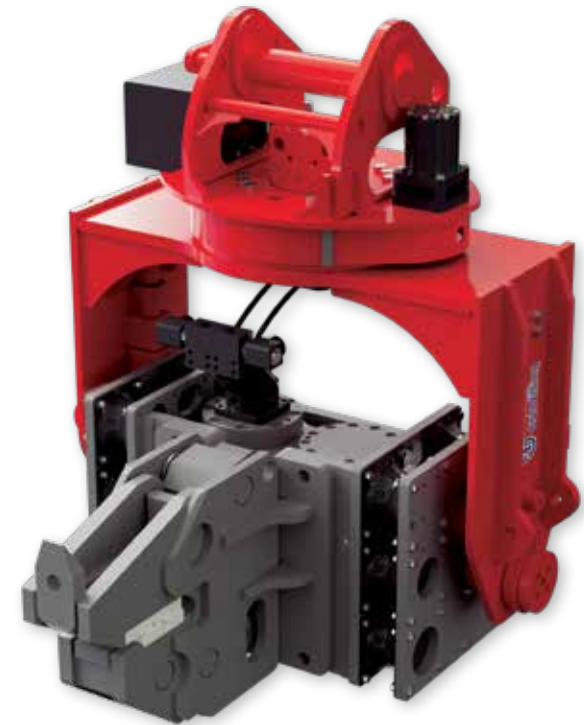

STERLING AUTO TILT HAMMER

Sterling Auto Tilt Hammer is an existing most robust tilt type hammer!

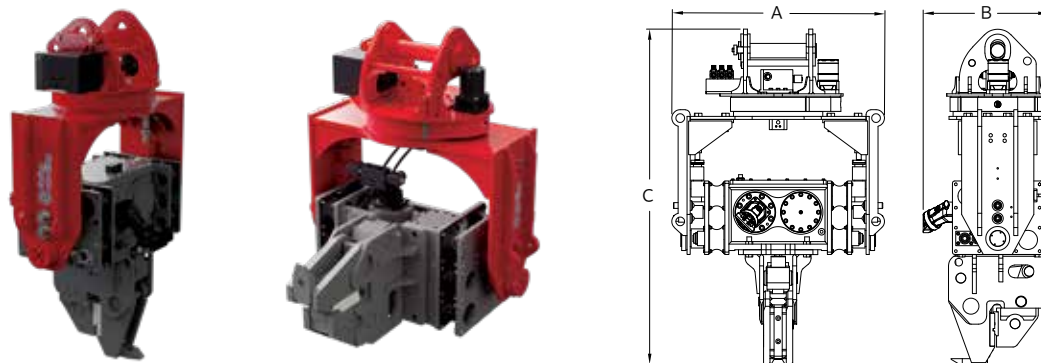

STRONG POINTS OF STERLING AUTO TILT HAMMER

- **More efficient and safer works**
 - 90-degree tilt / 360° hydraulic rotation function enable more efficient and safer works
- **“Auto Hold” function on 90-degree tilt position**
- **Low maintenance cost & Easy maintenance**
 - Compact design with no failure-prone cylinders of tilt function
- **Rigid and durability**
 - Durable structure and rigid rubber cushion
- **Low maintenance cost & easy maintenance**
 - Concise structure of components
- **Easy installation & operation**
 - Concise operation electric kits

Model	Unit	SH25 TILT	SH30 TILT	SH40 TILT
Suitable Excavator	ton	20 ~ 26	28 ~ 36	36 ~ 50
Weight (Incl. Mounting Cap)	kg	1,620	1,910	2,250
Extension Boom Weight	kg	498	600	714
Setting Pressure	bar	300	300	300
Oil Flow	lpm	170 - 200	180 - 220	240 - 260
Centrifugal force	kN	520	610	700
Frequency	bpm	2,800 ~ 3,600	2,800 ~ 3,600	2,200 ~ 2,800
Rotation	deg	360	360	360
Tilting degree	deg	90	90	90
Bottom Jaw open	mm	65	65	65
Dimension (A x B x C)	mm	1,326 x 711 x 2,089	1,326 x 805 x 2,089	1,435 x 900 x 2,180

※ Specifications above are subject to change without notice.



STERLING HAMMER

/ JOB APPLICATION

Significantly wider offering & 4 market segments enable further success

SEA SIDE



RIVER SIDE



SAND FIELD



WITH AUGER



STERLING HAMMER

Sterling Hammer is an existing most powerful hammer in the same class!

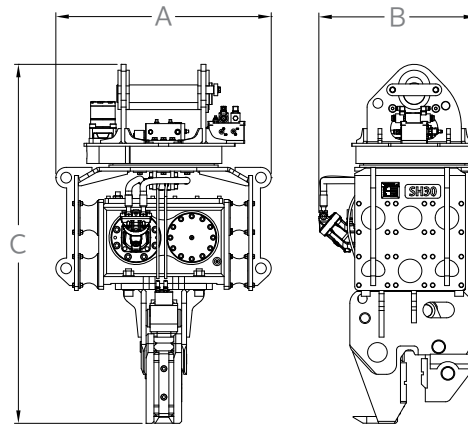

Model	Unit	SH25	SH30	SH40
Suitable Excavator	ton	20 ~ 26	28 ~ 36	36 ~ 50
Weight (Incl. Mounting Cap)	kg	1,520	1,810	2,050
Extension Boom Weight	kg	498	600	714
Setting Pressure	bar	300	300	300
Oil Flow	lpm	170 - 200	180 - 220	240 - 260
Centrifugal force	kN	520	610	700
Frequency	bpm	2,800 ~ 3,600	2,800 ~ 3,600	2,200 ~ 2,800
Rotation	deg	360	360	360
Bottom Jaw open	mm	65	65	65
Dimension (A x B x C)	mm	1,094 x 711 x 1,862	1,094 x 805 x 1,862	1,200 x 900 x 1,950

※ Specifications above are subject to change without notice.

STRONG POINTS OF STERLING HAMMER

- **Faster and more powerful**
 - Faster penetration and pulling up than other vibratory hammers thanks to bigger and centered eccentric weight
- **Easy maintenance**
- **Low maintenance cost**
 - Concise structure of components
- **Rotational mounting**
 - 360 hydraulic rotation system
- **Rigid and durability**
 - Durable structure and rigid rubber cushion
- **Easy installation & operation**
 - Concise operation electric kits



STERLING AUTO TILT HAMMER

STERLING HAMMER

WORKING RANGE - SH25 Tilt / SH30 Tilt / SH40 Tilt

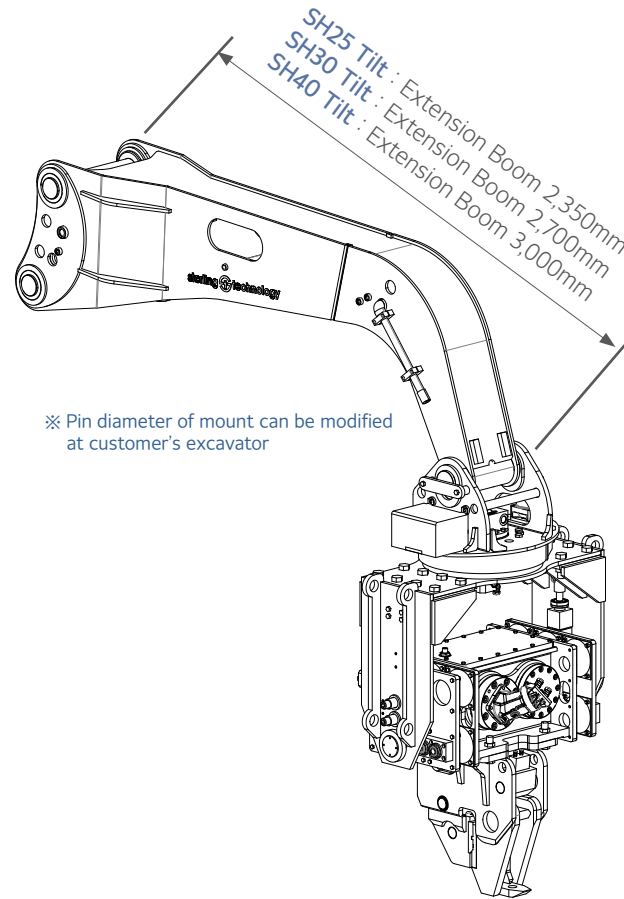

Model	Suitable Excavator
SH25 Tilt	20 ~ 26 ton
SH30 Tilt	28 ~ 36 ton
SH40 Tilt	36 ~ 50 ton

※ Specifications above are subject to change without notice.



STERLING RIPPER



/ JOB APPLICATION

Significantly wider offering & 4 market segments enable further success!

MINING



DOWNTOWN CONSTRUCTION



TUNNEL CONSTRUCTION



UNDER WATER OPERATION



STERLING RIPPER

Sterling Ripper literally means excellent and outstanding rock breaking equipment!

Sterling Ripper offers three options in **Tip type** for soft & medium hard-rock, **Chisel type** for hard-rock for hard-rock, and **Compactor type** for compacting ground. Single Sterling Ripper body has three optional tools! you can simply change it at site any time depending on rock types and various application!

Tip(tooth) type

Chisel type

Compactor type



UNIQUE CARTILAGE-LINK STRUCTURE AND ROBUST BEARING STRUCTURE OF STERLING RIPPER

- Maximizing productivity and minimizing down time by on-site parts replacement
- Minimizing vibration transmitted to excavator and operator even at hard-rock
- Keeping constant and high productivity at hard-rock job site
- Rigid and higher durability at hard-rock job site

Model	Unit	SR25	SR30	SR40	SR50	SR80
Operating weight	Kg	2,620	3,450	4,440	5,600	10,500
	lb	5,776	7,606	9,789	12,346	23,149
Dimension [A x B x C]	mm	787 x 1,148 x 2,870	863 x 1,321 x 3,231	915 x 1,401 x 3,385	1,060 x 1,554 x 3,665	1,404 x 1,600 x 4,100
	inch	30.98 x 45.20 x 112.99	33.98 x 52.01 x 127.20	36.02 x 55.16 x 133.27	41.73 x 61.18 x 144.29	55.28 x 63.00 x 161.42
Chisel diameter Ø	mm	110	120	130	140	180
	inch	4.33	4.72	5.12	5.51	7.09
2nd relief setting pressure**	Bar	250	250	280	280	300
	Psi	3,626	3,626	4,061	4,061	4,351
Operating pressure	Bar	180 - 220	180 - 220	210 - 250	210 - 250	240 - 270
	Psi	2,610 - 3,190	2,610 - 3,190	3,045 - 3,626	3,045 - 3,626	3,481 - 3,916
Oil flow	lpm	170 - 200	180 - 220	240 - 280	250 - 310	500 - 560
	gpm	45 - 53	47 - 58	63 - 74	66 - 82	132 - 148
Frequency	bpm	2,500 ~ 3,500	2,500 ~ 3,200	2,000 ~ 2,800	2,000 ~ 2,800	2,200 ~ 2,500
Air spring nitrogen pressure	Bar	4	5	5	5	5
	Psi	58	72	72	72	72
Suitable carrier	ton	20 ~ 26	28 ~ 34	36 ~ 43	46 ~ 60	70 ~ 90
	lb	44,092 ~ 55,115	61,729 ~ 74,957	79,366 ~ 94,798	101,412 ~ 132,277	154,323 ~ 198,416

※ Specifications above are subject to change without notice.

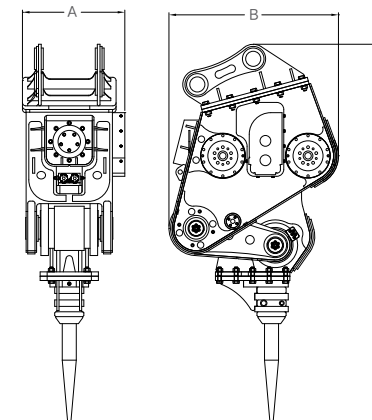

COMPARISON CHART

► Available equipment for rock hardness

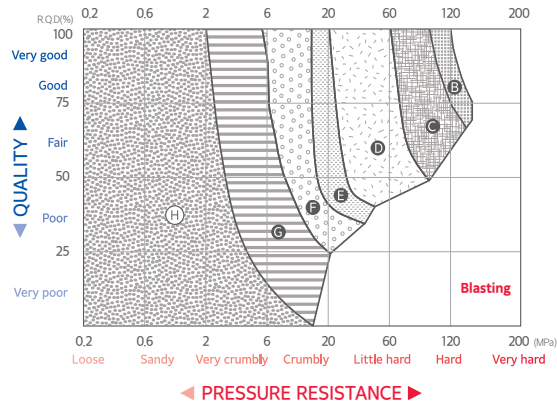

Big class Sterling Ripper can work well at hard-rock without problems most vibratory rippers have, thanks to its cutting-edge technology, Unique cartilage-Link

Model	B	C	D	E	F	G
Hyd. Breaker	•	•	•	•	•	•
Sterling Ripper	•	•	•	•	•	•
Vibro Ripper		•	•	•	•	•
Dozer				•	•	•
Bucket						•

► Sterling Ripper VS Hydraulic breaker

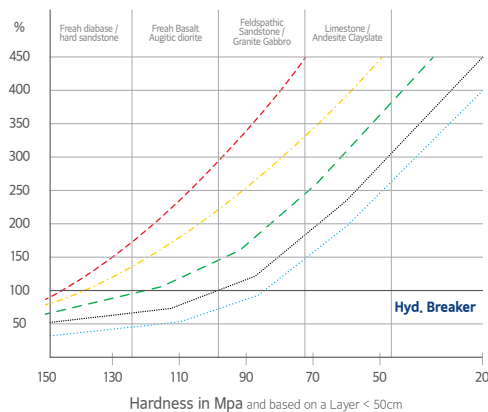

The bigger class of Sterling Ripper, the much higher productivity and hydraulic breaker up to soft medium hard-rock and perform well at hard-rock job site compared to hyd. breaker

	SR80
	SR50
	SR40
	SR30
	SR25

STRONG POINTS OF STERLING RIPPER

- **Higher productivity than hydraulic breaker**
 - 2 ~ 8 times better productivity than hyd. breaker depending on type of rocks
- **More powerful than other vibratory rippers**
 - Unique structure and design specially bigger and centered eccentric weight enable - Sterling Ripper most powerful Ripper in the same class
- **Selective tool options - Three tools for one Ripper**
 - Chisel type for hard rock, Tip(Tooth) type for soft & mid hard-rock and Compactor type for compacting ground
 - Three optional tools enables Sterling Ripper to offer wider selections of application than competitors at rock breaking job sites
- **Minimum vibration to excavator and operator at hard-rock**
 - Unique Cartilage-link of Sterling Ripper allows more powerful striking force but less vibration transmitted to excavator and operator
 - Less impact to excavator and less fatigue to operator
- **Minimum noise**
 - Sterling Ripper's Unique Cartilage-link structure technology allows minimum noise at max. 90db and downtown building construction can be done without restrictions
- **Easy on-site maintenance & low maintenance cost**
 - Concise structure of components and structure
 - Most parts can be replaced at job site
 - No need to return it to repair shop
 - Less number of parts than competitors enable low maintenance cost
 - Maximum productivity can be achieved by reducing down time by on site parts replacement and fast tip(Tooth) replacement
- **Under water operation without special devices**
 - All kinds of work under water can be done without any expensive and complicated preparations

NOTE

STERLING PEOPLE!
STERLING PRODUCTS!
STERLING SERVICE!



sterling  technology

www.sterlingripper.com Inquiry : sterling@sterlingripper.com

Copyright December 2023. Sterling Technology Inc. All right reserved.